

PRESENT STATUS OF SOLAR PHOTOVOLTAIC CELLS IN ASIA

S.A.A. Tarusan^{1,2}, M. Hasanuzzaman¹, M. Azri^{1,2}, N.A. Rahim¹

UM Power Energy Dedicated Advanced Centre (UMPEDAC), Level 4, Wisma R&D, University of Malaya,
Jalan Pantai Baharu, 59990 Kuala Lumpur, Malaysia
Faculty of Electrical Engineering, University of Technical Malaysia Melaka
76100 Durian Tunggal, Melaka, Malaysia
Email: hasan@um.edu.my

ABSTRACT

Solar energy is one the most popular renewable energy sources. In this paper, various types of photovoltaic cells, manufacturing countries, their efficiency of PV module and overall performance has been analysed and compared for the Asian countries. Data has been collected from the datasheets of various manufacturers in the Asian countries. It is found that the mono-crystalline cells have the better performance compared to multi-crystalline cells. Chinese manufacturers are the dominants for the mono-crystalline cell production with the efficiency of 20% and 18.48% of maximum and average respectively. The highest efficiency of multi-crystalline cell production is also achieved by Chinese manufacturers with the efficiency of 19% and 17.45% maximum and average respectively. But the highest fill factor is achieved by Taiwan manufacturers with 80.89% maximum and 79.36% average for monocrystalline cells and 79.91% maximum and 78.94% average for multi-crystalline cells. It is also found that during the period of 2009 to 2011 has achieved the highest production for all types of cells types as well as rate of production is increasing day-by-day.

Keywords: Renewable energy, solar energy, Photovoltaic cell, Fill factor.

NOMENCLATURE

B - Boltzman's constant
 FF - Fill factor
 I - Current (Amp)
 K - Diode ideality factor
 P - Power (Watt)
 PV - Photovoltaic
 q - Electron charge
 R - Resistance (Ohm)
 T - Temperature (K)
 V - Voltage (Volt)
 η - Efficiency (%)

Subscript

D- Diode
J - Solar cell
L - Load
M - Maximum
OC - Open circuit

S - Series

SC - short circuit

1. INTRODUCTION

Energy is the key input and basic need for development, economic growth, automation and modernization. However, global energy demands are increasing rapidly and this concern is addressed by international researchers on how to fulfill the future energy demand (Mondal and Islam 2012). Most countries are using fossil fuels that are limited source of energy and creating serious problems as global warming for the modern society. It is important to find an alternative to fossil fuel before this resource comes to an end. Solar energy is one of the energy source that is renewable and an alternative energy sources for clean and safe environment (Rahman, et al. 2015). Solar energy is abundant and widely used in terrestrial application (Hosenuzzaman et al. 2015). Photovoltaic (PV) cell has an important role to convert from solar energy to electricity and heat. Photovoltaic cells are several type with their own advantages and disadvantages that are competitive each other to achieve the best performance produced by cells manufacturer. Nowadays, photovoltaic technology grows rapidly in worldwide. Developed countries (i.e. America, Europe, Australia, China, Japan) have been applied the photovoltaic technology for development of the countries (Rang et al. 1990; Hashimoto 2003; Bachler 2006; Zahedi 2006; Mondal and Islam 2011). The developing countries (i.e. Malaysia, Thailand, and Vietnam) are starting the use of the PV technology (Jivacate and Buakhiew 2003; Johari et al. 2011). Photovoltaic technology is growing fast due to the awareness of climate change, thinner ozone layer and carbon emission (Applasamy 2011; Moosavian et al. 2011). Building integration of photovoltaic (BIPV) system is widely used in building to produce electricity and well as heat (Hongxing and Yuyan 2003). Solar lighting is one of the popular use rural areas (Sastry 2002; Honglian 2010). Photovoltaic also contributes to transportation such as highway camera surveillance system and vehicles (Melo et al. 2011). The standard principle of photovoltaic cell is based on mono-crystalline cell that has similar properties of solid-state devices such as diodes, bipolar transistor, field effect transistor etc. (Li et al. 2010). The photovoltaic cell is directly converted from solar radiation to electricity. Currently, photovoltaic cell can be categorized into

several types such as crystalline silicon, thin-film, dye-sensitized and organic cell. Crystalline silicon consists of mono-crystalline and multi-crystalline (Goetzberger et al. 2003; Miles et al. 2005). Monocrystalline and multi-crystalline are formed by silicon single crystal and silicon multiple crystals respectively. Nowadays, photovoltaic cells are getting competitive in the photovoltaic market (Bruton 2002; Jäger-Waldau 2004). Crystalline silicon cells are dominant solar cells in terms of efficiency with >20% leaving distant the second generation of photovoltaic cells; thin-film with <10% efficiency (Miles et al. 2005). Crystalline silicon cell is abundant element in crust of earth, non-toxic material and part of solid-state semiconductor as well as in microelectronic industry. Crystalline silicon cell is required a thick layer of wafer to absorb photons from light that makes it costly. Efficiency of mono-crystalline silicon cells higher but expensive (Miles et al. 2005). Multi-crystalline silicon cell is low cost production and less silicon consumption as well as easier manufacturing process than monocrystalline. As multi-crystalline are low cost, many researchers and manufacturers attempt to enhance its efficiency. The aim of the research is to analyze the production and performance of crystalline silicon cells in the Asian countries.

2. METHODOLOGY

2.1 Data source and collection

Crystalline silicon cells consist of mono-crystalline and multi-crystalline or polycrystalline. Data for these types of cells are collected from various manufacturer datasheet, catalogues and brochures available through internet in their company websites. Most of manufacturers are able to produce both types of crystalline solar cells (i.e. monocrystalline and multi-crystalline). Each type consists of two sub bus-bar; monocrystalline 2 bus-bars and monocrystalline3 bus-bar, and multi-crystalline 2 bus-bars and multi-crystalline3 bus-bar. There are 101 data samples have been used to evaluate the performance of crystalline cells. The crystalline silicon cells (i.e. mono-crystalline and multi-crystalline) are selected based on higher value achieved by manufacturers to evaluate cell performance. Overall, data of crystalline silicon cells are collected from 57 manufacturers which is available around worldwide. Then, data is included with country and year of solar cells production.

2.2 Data analysis

The general solar cell equivalent circuit is represented in Figure 1. Current generator acts as a solar cell junction placed parallel to ideal diode. Series resistance (R_s) and single-diode complete the solar cell circuit (Rodrigues, Melicio et al. 2012). Equation 1 (Rodrigues et al. 2012) below expresses the load current Equation 1 (Rodrigues, Melicio et al. 2012) below expresses the load current (I_L) by differentiation of current produced by solar cell (I_J) and diode current (I_D):

$$I_L = I_J - I_o(\exp[\frac{q}{BKT}(V + I_L R_s)] - 1) \dots (1)$$

Current produced by solar cell flows into diode and load once light initiation hit on solar cell. Since diode current is very small, it leads the high current flows into load even condition of short-circuit ($V=0$). It is similar with R_s which has very small value and has caused load to obtain high current from solar cell. Current produced by solar cell is therefore assumed as short circuit current $I_L = I_J$. Open circuit voltage (V_{OC}) is generated as the Equation 2 (Rodrigues et al. 2012) as below:

$$V_{OC} = \frac{BKT}{q} \ln(\frac{I_J}{I_o} + 1) \dots (2)$$

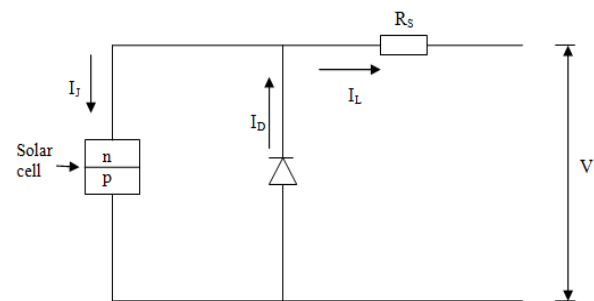

Figure 1 Equivalent circuit of solar cell (Rodrigues et al. 2012)

Important parameter related to solar cell is conversion efficiency. Maximum voltage (V_M) with maximum current (I_M) over power radiance from sunlight (P), yield conversion efficiency (η) can be calculated by using Equation 3 (Panjwani 2011):

$$\eta = \frac{I_M V_M}{P} \dots (3)$$

I-V characteristic curve is shown in Figure 2. The location of maximum voltage (V_M) intersect with maximum current (I_M) generates maximum output power. Irradiance used is normally based on standard test condition (STC) of Air Mass 1.5 spectrum in terrestrial application. Irradiance for Air Mass 1.5 spectrum is 1000 Wm^{-2} in 25°C temperature (Panjwani 2011; Kieu 2012). Then, another parameter considered is fill factor. Fill factor is the ratio of maximum voltage and current to short circuit current (I_{SC}) and open circuit voltage (V_{OC}) that can be calculated by using Equation 4 (Panjwani 2011; Kieu 2012):

$$FF = \frac{I_M V_M}{I_{SC} V_{OC}} \dots (4)$$

Fill factor can be used to calculate conversion efficiency by using Equation 5 (Panjwani 2011; Kieu 2012):

$$\eta = \frac{I_{sc}V_{oc}FF}{P} \dots\dots\dots(5)$$

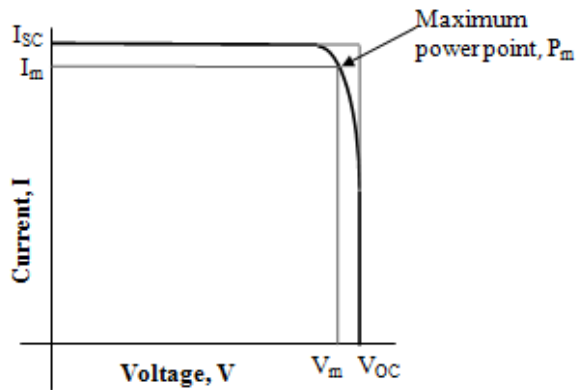

Figure 2 I-V characteristic (PVCCT 2012)

J-V characteristic can also be used for solar cell performance to represent short circuit current density (J_{sc}) (Teklu 2009). Some datasheets were not completed for the required parameter for this researcher. So, Equations 4 and 5 (Kieu 2012) are used to calculate related parameters to complete the data sheets.

3. RESULTS AND DISCUSSION

3.1 Solar cells production

All solar cells have same features in terms of dimension and several electrical specifications. The dimension of the cells are $156\text{mm} \times 156\text{mm} \times (200 \pm 30) \mu\text{m}$ in average and data available in supplier datasheet for each cell such as efficiency, maximum power, current maximum power, voltage maximum power, current short circuit, voltage open circuit and fill factor. In this research, 101 samples are collected randomly of mono-crystalline and multi-crystalline cells and the cell production percentage are 49% and 51%, respectively. Figure 3 shows the country based cell production and shows that Chinese manufacturers are the highest (about 69%) and Taiwan manufacturers with 24% of cell production. In Figure 4, China is the leading country in producing crystalline silicon cells with 35.16% monocrystalline and 30.69% multi-crystalline (i.e. 51% mono-crystalline and 49% multi-crystalline of China cells). Oppose to China, Taiwan produces 13.19% multi-crystalline which is higher than 10.99% monocrystalline cells (i.e. 55% multi-crystalline and 45% monocrystalline of Taiwan cells). Other countries produce both cells at same percentage with 3.3% (i.e. 50% multi-crystalline and 50% monocrystalline). Most manufacturers are able to produce both types of crystalline silicon cells.

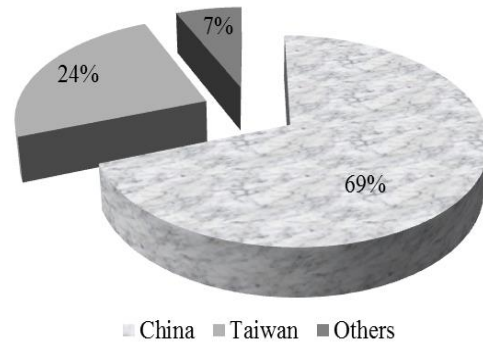

Figure 3 Asian countries based crystalline cells production

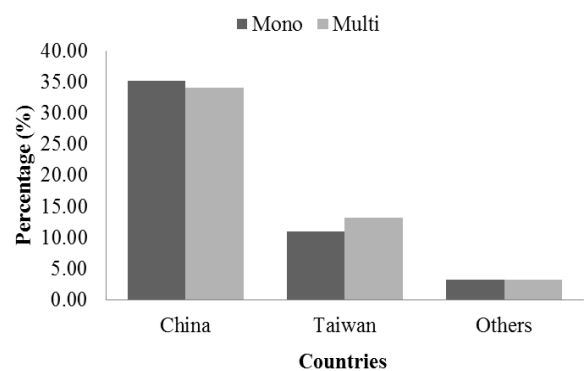

Figure 4 Cell type produced by Asian countries

In Figure 4, China is the leading country in producing crystalline silicon cells with 35.16% monocrystalline and 30.69% multi-crystalline (i.e. 51% mono-crystalline and 49% multi-crystalline of China cells). Oppose to China, Taiwan produces 13.19% multi-crystalline which is higher than 10.99% monocrystalline cells (i.e. 55% multi-crystalline and 45% monocrystalline of Taiwan cells). Other countries produce both cells at same percentage with 3.3% (i.e. 50% multi-crystalline and 50% monocrystalline). Most manufacturers are able to produce both types of crystalline silicon cells. Figure 4 Cell type produced by Asian countries The collected samples cells (manufactured year from 1997 to 2011) are also presented by producing year and country basis in figure 5. From Figure 5, it is clear that the most cells production occurred in 2009 to 2011 with 51%. The second range of year for solar cells production reaches 25% for 2006 to 2008. It is followed by 17% in 2003 to 2005. Subsequently, 2000 to 2002 achieves 3% of solar cells production.

Figure 5 further indicate that solar cells are the most produced during the period of 2009 to 2011. In this range of time period, China has been the highest country in producing solar cells of 47.25%. Leaving far behind is Taiwan with 4.4% while other countries have not produced any crystalline cells. The period of 2006 to 2008 is the second highest in producing solar cells. It

shows the peak country developing solar cells during this period is China with 15.38%. Subsequently, 10.99% crystalline solar cell is produced by Taiwan. Then, there is no crystalline cell produced by other countries during this period of year. The third period of years 2003 to 2005 shows 8.79% dominated by Taiwan in solar cell production. China produces crystalline solar cells with 6.59% while other countries produce 2.2%. In Figure 7, it shows other countries such as India and Japan have started producing cells during the period 1997 to 1999. Meanwhile, China and Taiwan have started to produce solar cell in range 2003 to 2005. It obviously shows crystalline solar cells production has grown rapidly by manufacturers in 2000s.

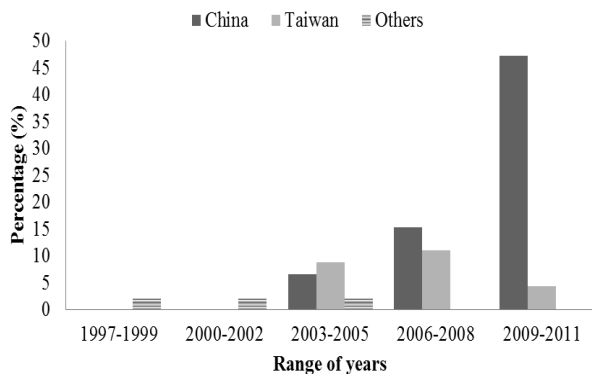

Figure 5 Crystalline solar cells produced based on country in range of year

The crystalline silicon cells produced in different ranges of years is shown in Figure 6. As expected, the period during 2009 to 2011 shows highly developing crystalline silicon cells. It is observed both crystalline silicon cells have same percentage of 25.49% of cell production. The second range of year in producing solar cells is 2006 to 2008. It shows that multi-crystalline is the highest produced with 12.75% leaving

0.09% difference of monocrystalline being 11.76%. It is followed by year range of 2003 to 2005 which 8.82% multi-crystalline is higher than 7.84% monocrystalline cell production. Subsequently, the productions of crystalline silicon cells are almost same during period 2000 to 2002 and 1997 to 1999. In Figure 6, it shows crystalline silicon cells have been started to produce in range of 1997 to 1999.

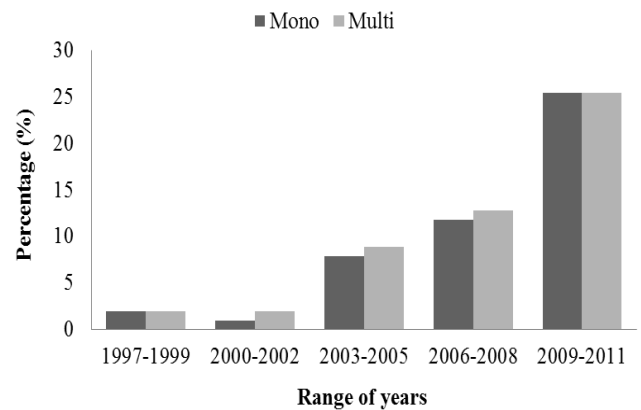

Figure 6 Type of solar cells produced in range of year

3.2 Performance parameter analysis of solar cells

The performances of the cells are analyzed through the efficiency achievement and fill factor. Figures 7 and 8 represent the percentage of cells efficiency and fill factor respectively. The mono-crystalline has the higher efficiency of 20% maximum and 18.48% average where the multi-crystalline has 19% maximum and 17.45% average efficiency cells produced by Chinese manufacturers. The mono-crystalline cell has the highest fill factor in maximum and average fill factor of 81.34% and 79.10% respectively. Both fill factor of multi-crystalline are slightly lower than monocrystalline cells of 80.06% maximum and 78.77% average respectively.

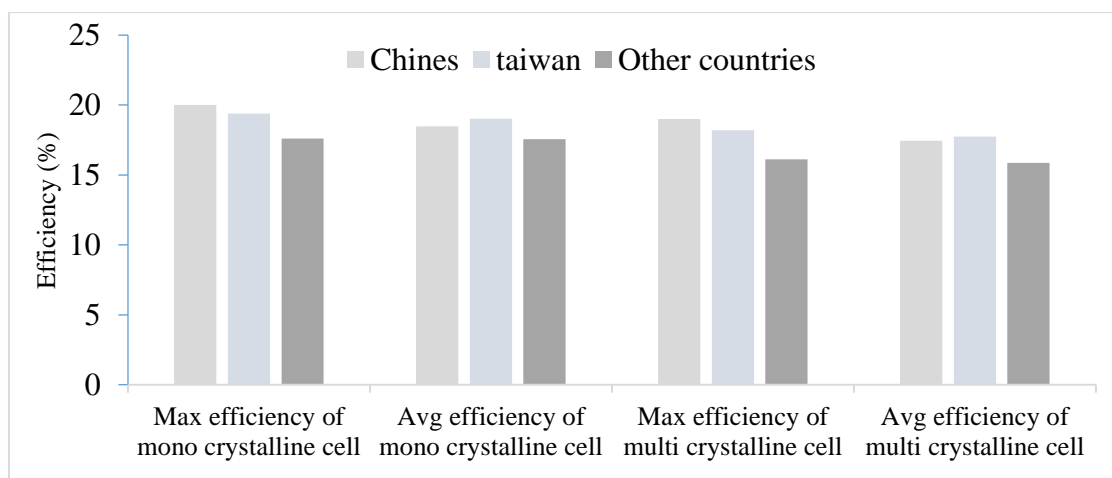

Figure 7 Efficiency achievement of cells produced by Chinese, Taiwan and other countries manufacturers

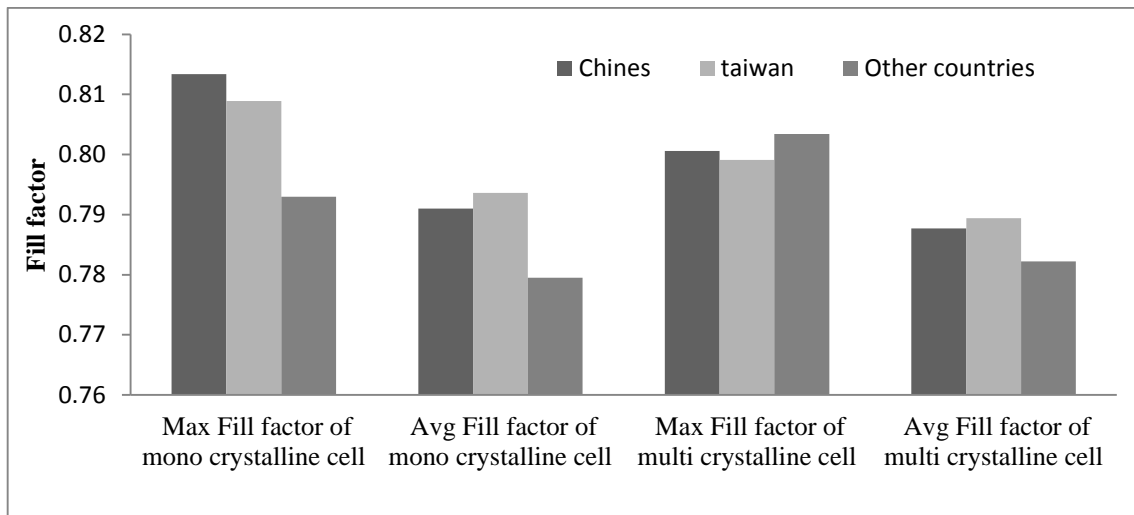

Figure 8 Fill factor achievement of cells produced by Chinese , Taiwan and other countries manufacturers

The mono-crystalline has higher efficiency of 19.4% in maximum and 19.03% in average than the multi-crystalline of in maximum 18.2% and 17.75% in average produced by Taiwan manufacturer's respectively. The fill factor of cells produced by Taiwan manufacturers are about 80.89% in maximum and 79.36% in average of mono-crystalline cells where 79.91% in maximum and 78.94% in average of multi-crystalline cells respectively. The mono-crystalline cells efficiency is about 17.6% where the multi-crystalline cells efficiency is about 16% product by other countries. It is also observed that the multi-crystalline cells fill factor is 80.34% in maximum and 78.22% in average. The maximum and average fill factor of monocrystalline cells are 79.3% and 77.95% respectively.

4. CONCLUSION

From the comparative analysis, it can be concluded that solar cells production rate is increasing very high (increase 92% by 14 years). Monocrystalline cells have the best performance compared to multi-crystalline cells. The maximum and average efficiency of mono-crystalline cells are 20% and 18.48% respectively manufactured by Chinese manufacturers. The maximum and average efficiency of multi-crystalline cells 19% and 17.45% respectively manufactured by Chinese manufacturers. The fill factor achieved is 80.89% maximum and 79.36% average for monocrystalline cells as well as 79.91% maximum and 78.94% average for multi-crystalline cells by Taiwan manufacturers.

ACKNOWLEDGEMENT

The authors would like to acknowledge the financial support from the University Malaya Research Grant scheme (Project No: RP016A-15SUS) to carry out this research.

REFERENCE

- Appalamy, V. 2011. Cost Evaluation of a Stand-alone Residential Photovoltaic Power System in Malaysia. IEEE Symposium on Business, Engineering and Industrial Applications: 214-218.
- Bachler, M. 2006. Grid Connected Systems in Europe – Looking into The Future." 4th IEEE World Conference on Photovoltaic Energy Conference: 2289-2292.
- Bruton, T. M. 2002. General trends about photovoltaics based on crystalline silicon." Solar Energy Materials and Solar Cells 72(1-4): 3-10.
- Goetzberger, A., C. Hebling, et al. 2003. Photovoltaic materials, history, status and outlook. Materials Science and Engineering: R: Reports 40(1): 1-46.
- Hashimoto, I. 2003. Present Status of Research and Development of PV Technology in Japan. Proceedings of the 3rd IEEE World Conference on Photovoltaic Energy Conference: 2522-2526.
- Honglian, Z. 2010. Development Application and Constraints of Photovoltaic Technology in China. Asia-Pacific Power and Energy Engineering Conference 1-4.
- Hongxing, Y. and F. Yuyan, 2003. Building-Integrated Photovoltaic Application-It's Practice in Hong Kong. Proceedings of the 3rd IEEE World Conference on Photovoltaic Energy Conference: 2490-2493.
- Hosenuzzaman, M., N. A. Rahim, et al. 2015. Global prospects, progress, policies, and environmental impact of solar photovoltaic power generation. Renewable and Sustainable Energy Reviews 41(0): 284-297.
- Jäger-Waldau, A. 2004. Status of thin film solar cells in research, production and the market. Solar Energy 77(6): 667-678.
- Jivacate, C. and C. Buakhiew 2003. Photovoltaic (PV): Status and Future Development in Thailand " Proceedings of the 3rd IEEE World

- Conference on Photovoltaic Energy Conference: 2553-2555.
- Johari, A., S. S. Hafshar, et al. 2011. Potential Use of Solar Photovoltaic in Peninsular Malaysia. IEEE First Conference on Clean Energy and Technology 110-114.
- Kieu, H. 2012. Photovoltaic Systems and Silicon Solar Cells, University of British Columbia. 13-23.
- Li, T., C. Jiang, et al. 2010. Research on New Technologies of Photoelectric Conversion Efficiency in Solar Cell. International Conference on Mechanic Automation and Control Engineering: 4002-4005.
- Melo, H. N. D., J. P. Trovao, et al. 2011. Batteries Usability for Electric Vehicle Powertrain. 3rd International Youth Conference on Energetics: 1-7.
- Miles, R. W., K. M. Hynes, et al. 2005. Photovoltaic solar cells: An overview of state-of-the-art cell development and environmental issues. Progress in Crystal Growth and Characterization of Materials 51(1-3): 1-42.
- Mondal, M. A. H. and A. K. M. S. Islam 2011. Potential and viability of grid-connected solar PV system in Bangladesh. Renewable Energy 36(6): 1869-1874.
- Mondal, M. A. H. and A. K. M. S. Islam 2012. Impacts of CO2 emission constraints on penetration of solar PV in the Bangladesh power sector. Renewable Energy 43(0): 418-422.
- Moosavian, S. M., N. A. Rahim, et al. 2011. Photovoltaic Power Generation: A Review. IEEE First Conference on Clean Energy and Technology: 359-363.
- Panjwani, D. R. 2011. Metal Blacks As Scattering Centers to Increase The Efficiency of Thin Film Solar Cells, University of Central Florida. 4-9.
- PVCCT 2012. NI, Part II – Photovoltaic Cell I-V Characterization Theory and LabVIEW Analysis Code, <http://www.ni.com/white-paper/7230/en>, (15/4/2012).
- Rahman, M. M., M. Hasanuzzaman, et al. 2015. Effects of various parameters on PV-module power and efficiency. Energy Conversion and Management 103(0): 348-358.
- Rang, Q. C., H. Y. Jin, et al. 1990. Development of Photovoltaic in China – Status and Future. 21st IEEE Photovoltaic Specialists Conference: 1011-1013.
- Rodrigues, E. M. G., R. Melicio, et al. 2012. Simulation of a Solar Cell considering Single-Diode Equivalent Circuit Model, <http://download.ebooks6.com/Simulation-of-a-Solar-Cell-considering-Single-Diode-Equivalent-pdf-e18668.pdf>, (3/9/2012).
- Sastry, E. V. R. 2002. The Photovoltaic Program in India. 29th IEEE Photovoltaic Specialists Conference: 28-31.
- Teklu, N. (2009). Study The Effect of Ultraviolet Radiation on Polycrystalline Silicon Solar Cell, University of Addis Ababa, Ethiopia: 15-32.
- Zahedi, A. 2006. Solar photovoltaic (PV) energy; latest developments in the building integrated and hybrid PV systems. Renewable Energy 31(5): 711-718.